

IN THE UNITED STATES DISTRICT COURT
FOR THE WESTERN DISTRICT OF WISCONSIN

NATIONAL PRODUCTS, INC.,

Plaintiff,

v.

OPINION AND ORDER

20-cv-439-wmc

PROCLIP USA, INC., and BRODIT AB.

Defendants.

Defendants ProClip USA, and Brodit AB moved for summary judgment on the grounds that (1) all of the patents-in-suit are invalid and (2) their products are non-infringing. (Dkt. #105.) Plaintiff National Products, Inc. (“NPI”), filed its own motion for partial summary judgment to resolve the patents’ priority dates before trial, as well as dispose of defendants’ indefiniteness defense.¹ The court now takes up summary judgment, as well as some assorted evidentiary motions. For the reasons given below, the court denies in part and grants in part each parties’ motion for summary judgment.

UNDISPUTED FACTS²

A. The Parties

Defendant Brodit manufactures mounting solutions for electronic devices, such as phone, tablet or laptop cases that can easily clip onto a car dashboard and continue to

¹ Plaintiff also moved to file a reply in support of its own proposed findings of fact (dkt. #152) which is granted here and was considered in deciding the parties’ summary judgment motions.

² Unless otherwise noted, the following facts are material and undisputed. Given the voluminous number of proposed findings, the court limits this section to the key, overarching facts and addresses other undisputed facts as relevant to specific arguments addressed in the opinion that follows.

function. ProClip is the exclusive importer and distributor of Brodit products in North America. Plaintiff NPI produces similar cases for electronic devices that allow for easy charging without removing the case (sometimes also described by NPI as the seeming misnomer of a “cover”).

B. Patents-in-Suit

NPI alleges that the defendants manufacture and sell products that infringe the following, three patents: 10,454,515 (“the ‘515 patent”), 9,706,026 (“the ‘026 patent”), and 10,778,275 (“the ‘275 patent”), collectively the “patents-in-suit.” Each patent describes cases for electronic devices that allow for easy charging.

The ‘026 application issued July 11, 2017, from U.S. Application Serial Number 14/936,517 originally filed on November 9, 2015. The ‘515 application issued October 22, 2019, from U.S. Application Serial Number 16/233,635, filed on December 27, 2018. The ‘275 application issued September 15, 2020, from U.S. Application Serial Number 16/854,828, filed on April 21, 2020. Each of the patents-in-suit claim to be a continuation of provisional application No. 61/943,986 (“the ‘986 application”), which was originally filed on February 24, 2014. Finally, “Jeffrey D. Carnevali” is named as the sole inventor of all three patents.

NPI asserts infringement of the following claims in the patents-in-suit:

Patent	Claim(s)
‘026	1, 2, 4, 6, 10, 11, 14, 15, 17, 18 and 19
‘275	1, 2, 3, 4, 5, 7, 8, 10, 11, 12, 13, 14, 15, 16, 17, 18 and 19
‘515	1, 2, 3, 4, 8, 9, 11, 12, 13, 14, 18 and 19

However, defendants argue that NPI has failed to submit sufficient evidence to support any claim of infringement. In response to defendants' motion, NPI not only disputes this, but has submitted additional, proposed findings of fact to support its infringement claims. (Pl.'s PFOFs (dkt. #104).) The parties also propose additional facts relevant to various of defendants' invalidity challenges. As already explained above, the court will address these proposed facts to the extent material to the court's findings in the opinion below, rather than merely reciting them in detail out of context to the material issues at summary judgment.

OPINION

I. Preliminary Matters

A. Supplemental expert report

As a preliminary matter, defendants ask for leave to supplement their designated expert Jason Stigge's report, adding some 3 pages of information in response to plaintiff's supplemental infringement contentions. (Defs.' Mot. (dkt. #119) 4.) Defendants further argue that they had already disclosed the information from this supplement to plaintiff, reducing the chance that the addition of this supplemental information to Stigge's report is prejudicial. (Defs.' Mot. (dkt. #119) 4.) Finally, defendants note that they did *not* rely on this proposed supplement in seeking summary judgment and should not require any extra discovery. (Defs.' Mot. (dkt. #119) 6.) In response, plaintiff argues that defendants' wait of nearly a year before moving to supplement Stigge's report with this information amounts to unfair surprise.

Regarding timing, the fact that defendants had this allegedly relevant information for this supplement for months does not lean in defendants' favor. The longer defendants waited, the more prejudicial the current motion would be to plaintiff. Even though plaintiff was aware of the underlying information, they were also entitled to know whether or not an expert was going to opine on those infringement contentions in advance of dispositive motions.

Plaintiff also notes that the Stigge supplement merely incorporates by reference defendants' invalidity contention chart. (Pl.'s Opp'n. (dkt. #127) 2.) While the Seventh Circuit has not spoken on this subject, several district courts have. *See Promega Corp. v. Applied Biosystems, LLC.*, No. 13-CV-2333, 2013 WL 9988881, at *5 (N.D. Ill. May 28, 2013), *aff'd sub nom. Promega Corp. v. Applied Biosystems, LLC*, 557 F. App'x 1000 (Fed. Cir. 2014) (finding that, "[e]xperts may not merely rubber stamp a lawyer's argument"); *Changzhou Kaidi Elec. Co. v. Okin Am., Inc.*, 112 F. Supp. 3d 330, 339 (D. Md. 2015) (preventing an expert from opining on invalidity contentions not in his original report when he simply incorporated the contentions by reference); *but see CoreLogic Info. Sols., Inc. v. Fiserv, Inc.*, No. 2:10-CV-132-RSP, 2012 WL 4761739, at *2 (E.D. Tex. Sept. 20, 2012) (allowing in the opinion but noting that, "[t]he Court finds it troubling that Dr. Snow relies on Defendants' invalidity contentions to satisfy" his written requirements). Given the cursory nature of Stigge's disclosure, which provides almost no analysis beyond prior attorney argument, and the egregiously long time defendants waited to supplement, the request to supplement is denied.

B. Strike undisclosed expert report

Second, defendants have moved to strike plaintiff's late-disclosed expert report from James Babcock. (Defs.' Br. (dkt. #138) 3.) The report is 121 pages long and was filed on November 19, 2021, at the same time plaintiff filed its brief in opposition to defendants' request for summary judgment. Defendants argue that the report is untimely and is not substantially justified or harmless. (Defs.' Br. (dkt. #138) 3.) Given the weakness of plaintiff's argument and the seemingly retaliatory nature of the report, the court agrees, and will strike the declaration of James Babcock. (Dkt. #129.)

Under Rule 37(c)(1), "[i]f a party fails to provide information or identify a witness as required by Rule 26(a) or (e), the party is not allowed to use that information . . . unless the failure was substantially justified or is harmless." Here, the offered report is neither justified nor harmless. Notably, plaintiff practically acknowledges that it filed Babcock's report as a retaliatory measure. In its brief, plaintiff stated that "the Court should exclude (1) ProClip's invalidity contentions not contained in Mr. Stigge's August 6 report, (2) the declarations and exhibits ProClip never previously disclosed, and (3) Mr. Stigge's proposed supplement. With these withdrawn, NPI will withdraw the Babcock Declaration." (Pl.'s Opp'n (dkt. #150) 2-3.) While parties unfortunately do not always hew to this principle, motions to strike are not meant as a cudgel with which to bully the other side. Plaintiff had the opportunity to oppose defendants' motion to supplement the Stigge report (dkt. #127) or file its own motions regarding documents it found inappropriate. Instead, plaintiff filed a never-before-disclosed 121-page expert report *in the middle of* summary judgment briefing, presumably to pressure defendants into withdrawing their own filings.

The standard for allowing a supplemental report is not whether the other side deserves to be inconvenienced; it is whether the report is harmless and substantially justified. Plaintiff barely makes an argument to that effect, facetiously arguing that the declaration is a rebuttal. Given the clear prejudice that the report poses, it is struck.

C. Claims Construction

“An infringement analysis entails two steps. The first step is determining the meaning and scope of the patent claims asserted to be infringed . . . The second step is comparing the properly construed claims to the device accused of infringing.” *Markman v. Westview Instruments, Inc.*, 52 F.3d 967, 976 (Fed. Cir. 1995), *aff’d*, 517 U.S. 370 (1996). Determining the meaning and scope of a patent may require what is known as claims construction, something “the Supreme Court has repeatedly held . . . is a matter of law exclusively for the court.” *Id.* at 977 (citing *Hogg v. Emerson*, 47 U.S. 437, 484 12 L. Ed. 505 (1848)). In claims construction, the court must “consider three sources: the claims, the specification, and the prosecution history.” *Unique Concepts, Inc. v. Brown*, 939 F.2d 1558, 1561 (Fed. Cir. 1991). While the specification is important, “[f]irst, we look to the words of the claims themselves.” *Vitronics Corp. v. Conceptoronic, Inc.*, 90 F.3d 1576, 1582 (Fed. Cir. 1996). “As a starting point, we give claim terms their ordinary and accustomed meaning as understood by one of ordinary skill in the art.” *Dow Chem. Co. v. Sumitomo Chem. Co.*, 257 F.3d 1364, 1372 (Fed. Cir. 2001).

In this case, plaintiff’s expert suggests that a person of ordinary skill in the art (“POSITA”) would be “an engineer or a product designer with approximately two or more years of experience with mechanical design and manufacturing that is obtained through

vocational studies, from working in the mechanical arts, or a combination of both.” (Babcock Report (dkt. #84) ¶ 27.) Defendants similarly suggest that a POSITA would have: “(1) a Bachelor’s Degree in mechanical engineering or a related discipline and at least two years of professional experience working with electronic products and/or electrical connectors, *or* (2) five years or more of experience in the design or development of electronic products and/or electrical connectors.” (Stigge ‘026 Report (dkt. #81) ¶ 60 (emphasis added).) Given that defendants’ definition appears to encapsulate plaintiff’s, the court will accept that definition.

With that understanding of a POSITA, the court turn to construing the relevant disputed terms as raised by the parties.

1. Cover

The first claim to construe is the word “cover,” which defendants would define as “[a] sheath molded of a suitable elastic or flexibly resilient elastomer, such as but not limited to vinyl, in a size and shape to fit over and closely conform to the smartphone, tablet or other portable electronic device 1 so that the cover 100 fits the device 1 like a surgical glove.” (Defs.’ Op. Br. (dkt. #105) 24.) Unsurprisingly, plaintiff defines “cover” more broadly to include “a protective housing adapted to substantially envelop the exterior boundaries of an electronic device.” (Pl.’s Opp’n. (dkt. #136) 8.) The word “cover” is used in claims 1, 10, 14, and 19 of the ‘026 patent and claims 1, 2, 4, 5, 12, and 14 of the ‘275 patent. No construction is required for this term in the ‘515 patent because it contains a dependent claim that explicitly describes the cover as “flexible”; however, neither the ‘026 or ‘275 patents use such language in the claims section.

Defendants’ principal argument for their construction is the patents’ apparent disavowal of a non-flexible cover in the specification.³ As a general principle, the Federal Circuit “has repeatedly cautioned against importing limitations from an embodiment into the claims.” *TomTom, Inc. v. Adolph*, 790 F.3d 1315, 1328 (Fed. Cir. 2015). Moreover, “[d]isavowal requires that ‘the specification [or prosecution history] make[] clear that the invention does not include a particular feature,’ or is clearly limited to a particular form of the invention.” *Hill-Rom Servs., Inc. v. Stryker Corp.*, 755 F.3d 1367, 1372 (Fed. Cir. 2014) (quoting *SciMed Life Sys., Inc. v. Advanced Cardiovascular Sys., Inc.*, 242 F.3d 1337, 1341 (Fed.Cir.2001)).

Still, the Federal Circuit has also explained that: “the specification is always highly relevant to the claim construction analysis. Usually, it is dispositive; it is the single best guide to the meaning of a disputed term.” *Vitronics Corp.*, 90 F.3d at 1582. Ultimately, “[w]e depart from the plain and ordinary meaning of claim terms based on the specification in only two instances: lexicography and disavowal.” *TomTom*, 790 F.3d at 1328. Thus, the Federal Circuit has

held that disclaimer applies when the patentee makes statements such as “the present invention requires ...” or “the present invention is ...” or “all embodiments of the present invention are...” . . . We have also found disclaimer when the specification indicated that for “successful manufacture” a particular step was “require[d].” . . . Likewise, we found disclaimer limiting a claim element to a feature of the preferred embodiment when the specification described that feature as a

³ Defendants also suggest that the cover must be “unitary.” (Defs.’ Op. Br. (dkt. #105) 28.) Given that the “unitary” requirement is even less supported by the text of the patent than the flexibility requirement, it, too, will not be read into the definition. Still, the same disavowal analysis would apply to either requirement.

“very important feature ... in an aspect of the present invention” and disparaged alternatives to that feature.

Hill-Rom Servs., Inc., 755 F.3d at 1372 (citations omitted)

Here, the specifications in both the ‘275 and ‘026 patents explicitly state that, “Cover 100 of **the present invention** is a sheath molded of a suitable elastic or flexibly resilient elastomer.” Patent ‘026 6:56-58; Patent ‘275 7:14-16 (emphasis added). The Federal Circuit has consistently held that use of language such as “the present invention is” or “consists of” may justify reading that limitation from the specification into the claim. *E.g., Honeywell Int’l, Inc. v. ITT Indus., Inc.*, 452 F.3d 1312, 1318 (Fed. Cir. 2006); *Edwards Lifesciences LLC v. Cook Inc.*, 582 F.3d 1322, 1330 (Fed. Cir. 2009); *SciMed Life Sys., Inc.*, 242 F.3d at 1343.

Additionally, the ‘275 and ‘026 patents regularly describe the cover as “flexible” or “elastomeric.” Looking at the ‘275 patent alone, the court was able to find at least 55 instances where the adjectives were used in conjunction with “cover.” For example, the ‘275 abstract mentions that “[a] protective arrangement for an electronic device includes a flexible cover.” ‘275 Patent 1. Similarly, the field of the invention section is described as “relat[ing] to a cover for protecting a portable electronic device, and in particular, to a flexible cover.” ‘275 Patent 1:33-35. Finally, the summary of the invention states that, “[o]ne aspect of the invention is a protective arrangement for an electronic device that includes a flexible cover.” ‘275 Patent 1:55-56. Given this ubiquitous use, defendants argue that plaintiff intended for invention as a whole to have a flexible cover, and the requirement should be read into the claims.

This argument is a close call given the hazy standard for limitations arising out of limitations in a specification. Ultimately, however, the Federal Circuit has required more supporting evidence before reading in a limitation than is found here. For instance, the Federal Circuit noted “the written description uses language that leads us to the conclusion that a fuel filter is the only ‘fuel injection system component’ that the claims cover . . . [as] on at least four occasions, the written description refers to the fuel filter as ‘this invention’ or ‘the present invention’.” *Honeywell Int’l, Inc.*, 452 F.3d at 1318. In contrast, while the “present invention” language is used in the NPI patents, it is not used as often or consistently as in *Honeywell*, providing a weaker argument for reading in this limitation.

There are several other elements that the Federal Circuit has emphasized besides the “present invention” language in deciding to read in a limitation from the specification into a claim. First, the Federal Circuit has looked at whether a specification emphasizes the *importance* of such a limitation or disparages alternatives without it. For instance, the Federal Circuit noted in *Andersen Corp. v. Fiber Composites, LLC*, 474 F.3d 1361, 1367 (Fed. Cir. 2007), the importance of the specification “mak[ing] clear that the formation of linear extrudates or pellets is not merely a preferred embodiment, but is a *critical element in the process*.” *Id.* (emphasis added). Obviously, that language suggested embodiments made without this “critical element” would not be effective. Similarly, in *declining* to read in a limitation in *Apple Inc. v. Wi-LAN Inc.*, 25 F.4th 960, 968 (Fed. Cir. 2022) the Federal Circuit noted the absence of “any statements expressing the advantages, importance, or essentiality of using a CPE as opposed to a subscriber unit.” Though the NPI patents

regularly describe the cover as flexible, *nothing* in the specification suggests that having a flexible cover is essential, nor are particular disadvantages with a rigid cover identified.

Second, the Federal Circuit looks for some support for narrower construction in the claims themselves. *E.g., Regents of Univ. of Minnesota v. AGA Med. Corp.*, 717 F.3d 929, 937 (Fed. Cir. 2013) (affirming a narrow claims construction where “the district court’s construction is faithful to the ordinary meaning of the language of claim 1”); *Edwards Lifesciences LLC.*, 582 F.3d at 1330 (holding that “the claim language itself supports the district court’s construction”). Here, defendants have been unable to point to any such language. To the contrary, the fact that the ‘515 patent describes the case as “flexible” in *dependent* claims, suggests that its omission in the independent claims in the ‘515 patent, as well as the ‘275 and ‘026 patents, was intentional. (Pl.’s Opp’n. (dkt. #136) 9.) Thus, plaintiff argues persuasively that reading flexibility into the other patents’ claims would render the ‘515 language dependent claim language extraneous. (*Id.*) While not dispositive, this is certainly an additional factor cautioning against reading into the term “cover” an unstated limitation.

Third, the Federal Circuit looks for support in the patent “prosecution history.” *Regents of Univ. of Minnesota v. AGA Med. Corp.*, 717 F.3d 929, 936 (Fed. Cir. 2013). Here, neither side directs the court’s attention to the patent prosecution history, suggesting there is nothing in that history that would support a broader *or* narrower reading of the term “cover.”

Ultimately, the Federal Circuit has shown a strong preference for not reading limitations from the specification into the claims, and the patents here do not provide a

sufficient basis to do so here. Without any of the other factors noted above, the fact that the patent repeatedly describes the cover as flexible alone simply is not enough.

There are no magic words that must be used, but to deviate from the plain and ordinary meaning of a claim term to one of skill in the art, the patentee must, with some language, indicate a clear intent to do so in the patent.

Hill-Rom Servs., Inc., 755 F.3d at 1373. As in *Hill-Rom*, “there is no such language here.”

As such, the term “cover” will be construed without in accordance with plaintiff’s proposal: “a protective housing adapted to substantially envelop the exterior boundaries of an electronic device.”⁴

2. Adapter

Defendants next ask the court to construe the word “adapter” used in claims 1, 2, 11, 12, and 14 of the ‘515 patent to include a limitation for being “fixedly positioned” in the protective shell. (Defs.’ Op. Br. (dkt. #105) 24.) Again, defendants’ argument for this construction is disavowed by references to a fixed adapter in the specification. (*Id.*) However, defendants once again can point to *no* support in the patent’s prosecution history or claims language supporting its proposed limitation. Additionally, there are far fewer references to the limit than to a flexible cover, making this argument even weaker. As such, defendants’ construction is improperly narrow, and the court construes an “adapter”

⁴ Defendants also argue that the following terms include a requirement of flexibility: “panel,” used in claims 1 and 2 of the ‘275 patent, and “skirt,” used in claim 1 of the ‘275 patent. (Joint Claims Cons. (dkt. #70) 9.) Given that there is *even less* basis to support reading in this limitation for these terms in the patents-in-suit than for the term “cover,” the court rejects this argument as well. As such, both “panel” and “skirt” should be construed under their plain and ordinary meaning to someone of ordinary skill in the art.

according to its plain and ordinary meaning without the limitation that it be “fixedly positioned.”⁵

II. Defendants’ Motion for Summary Judgment

Summary judgment must be granted against a party who fails to make a showing sufficient to establish the existence of an element essential to a party’s claims on which that party has the burden of proof. *Celotex Corp. v. Catrett*, 477 U.S. 317, 323 (1986). If there is any genuine issue of material fact on the element, however, the court cannot grant summary judgment. *Id.* A dispute is genuine “if the evidence is such that a reasonable jury could return a verdict for the non-moving party.” *Anderson v. Liberty Lobby, Inc.*, 477 U.S. 242, 248 (1986) (citation omitted). Finally, “[t]he evidence of the non-movant[s] is to be believed, and all justifiable inferences are to be drawn in [their] favor.” *Id.* at 255.

Here, defendants move for summary judgment on three theories: (1) certain material terms in the patents-in-suit are improperly indefinite; (2) the accused products do not infringe the patents; and (3) the relevant patents actual priority dates did not predate certain ProClip or third-party products.

A. Indefiniteness

Defendants argue that the following terms are improperly indefinite. A patent is invalid for indefiniteness “if its claims, read in light of the specification delineating the

⁵ Defendants also argue the following terms are required to be “fixedly positioned”: “male plug,” “contactor,” and “electrical conductor.” (Defs.’ Op. Br. (dkt. #105) 24-32.) Given the scant evidence for such limitations, the court also construes these terms according to their plain meaning without such a limitation.

patent, and the prosecution history, fail to inform, with reasonable certainty, those skilled in the art about the scope of the invention.” *Nautilus, Inc. v. Biosig Instruments, Inc.*, 572 U.S. 898, 901 (2014). “The definiteness requirement, so understood, mandates clarity, while recognizing that absolute precision is unattainable.” *Id.* at 910. Additionally, “a claim is not indefinite just because it is broad.” *Niazi Licensing Corp. v. St. Jude Med. S.C., Inc.*, 30 F.4th 1339, 1347 (Fed. Cir. 2022). This court has previously noted that, “like other invalidity challenges, a party asserting [indefiniteness] bears the burden of proving invalidity by clear and convincing evidence.” *Plastipak Packaging, Inc. v. Premium Waters, Inc.*, No. 20-CV-098-WMC, 2021 WL 3675151, at *13 (W.D. Wis. Aug. 19, 2021) (citing *Microsoft Corp. v. i4i Ltd. P'ship*, 564 U.S. 91, 97 (2011)). “Indefiniteness may result from inconsistent prosecution history statements where the claim language and specification on their own leave an uncertainty that, if unresolved, would produce indefiniteness.” *Infinity Computer Prod., Inc. v. Oki Data Americas, Inc.*, 987 F.3d 1053, 1059 (Fed. Cir.), *cert. denied*, 142 S. Ct. 585 (2021)

1. “Male Connector” (‘026 Patent, Claim 1; ‘515 Patent, Claim 1); “Male Portion” (‘026 Patent, Claim 11); and “Male Nesting Appendage” (‘275 Patent, Claims 2, 3, 12, 16, 17, and 20)

Defendants first argue that various terms regarding male connectors are indefinite, as the difference between the male and female connectors are not clearly delineated. While arguing that the terms “male connector,” “male portion,” and “male nesting appendage” need not be construed at all (Pl.’s Opp’n. (dkt. #136) 58), plaintiff alternatively suggests that a male connector is “a connector that protrudes from the surrounding area for mating with a connector having a complementary shaped inward recess.” (Joint Claims

Construction (dkt. #70) 3.) Similarly, a female connector would then be “an inwardly recessed connector for mating with a complementary shaped protruding connector.” (Id. 5.)

In contrast, defendants’ expert points out that the “male connector” as shown by the ‘026 patent has its prongs recessed inside of a dam to prevent damage to the prongs, while the “female connector has contacts which project out. (Stigge Report (dkt. #81) 42-43.) By having a recessed “male connector” and a protruding “female connector,” the actual meaning of these terms is arguably confused. “Female connector” as shown by the ‘026 patent:

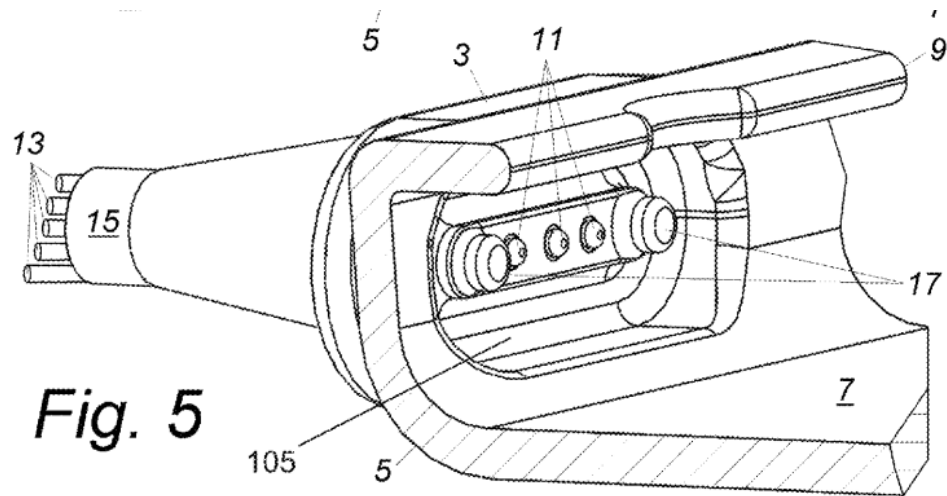

“Male Connector” as shown by the ‘026 patent:

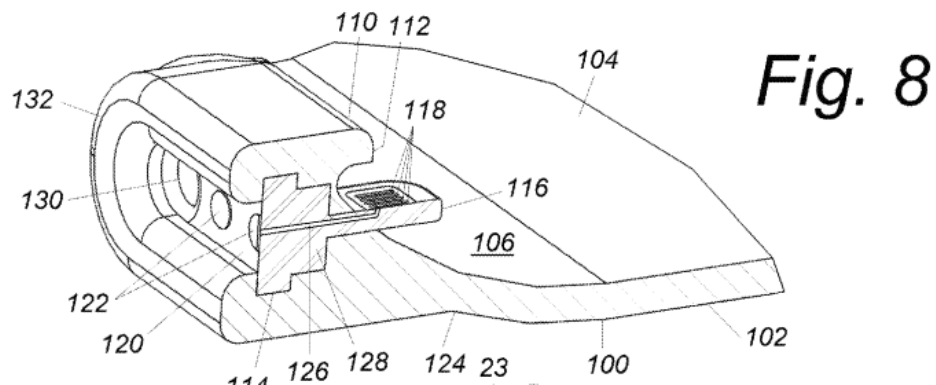

While these two appear to illustrate connectors with portions that are recessed and other portions that protrude, somewhat blurring the line between female and male, this does not seem to be unusual with electric couplings. For instance, “certain electronic connector designs may incorporate combinations of male and female pins in a single connector body, for mating with a complementary connector with opposite gender pins in corresponding position in such cases, gender is often defined by the shape of the connector body, rather than the mixed-gender connector pins and sockets.” Gender of Connectors and Fasteners, June 20, 2022, https://en.wikipedia.org/wiki/Gender_of_connectors_and_fasteners.

More importantly, the patents each show, through words and figures, which connectors are considered male and which are considered female. Generally, throughout the entirety of the patent, protruding *walls* of the connector create a male connector, as opposed to the recessed position of the prongs that create a female connector. Taken in isolation, one may not be sure that an unusual connector is male *or* female, but the court’s

obligation is not to look at rare figures in isolation; instead, the question is whether a POSITA would understand the term of the “claims, read in light of the specification delineating the patent, and the prosecution history.” *Nautilus, Inc.*, 572 U.S. at 901. If the patent identified one connector as female while later identifying the same connector as male, that may be stronger grounds to find indefiniteness. However, that is not the case in any of the patents-in-suit.

For the terms “male connector” and “male portion,” defendants also suggest they are indefinite because these terms do not appear anywhere in the specification and are only listed in the claims section. (Defs.’ Op. Br. (dkt. #105) 78.) While not having a term in the specification may make it harder for a POSITA to understand a term, “[t]he mere observation of information not ‘recited’ does not answer the question whether a person of ordinary skill in the art would need to be given [additional] information to understand, with reasonable certainty.” *BASF Corp. v. Johnson Matthey Inc.*, 875 F.3d 1360, 1366 (Fed. Cir. 2017). Again, reading the claims in the context of the patent as a whole, a POSITA should understand that a connector as contemplated by the patent is male when the outer walls surrounding the connectors protrude outwards, even if the contactors themselves may be recessed within the walls.

2. “Female Connectors” (‘026 and ‘272 Patents) and “Female Base Receiver” (‘515 Patent, Claims 9 and 19)

Defendants make the same indefiniteness argument with regard to the female connectors, but the arguments are equally unavailing. Indeed, so long as the male and female connectors are mirror images of each other, a POSITA would likely not need more

information to practice the patent. Regardless, each of these terms will be defined as proposed by plaintiff: “Female connector,” “male connector,” “female portion,” “male portion,” “female nesting appendage,” “male nesting appendage.”

Defendants next argue that the term “female base receiver” is indefinite as it is not defined in the patent specification. As previously noted, the fact that a term is not defined in the specification is not dispositive, *BASF Corp.*, 875 F.3d at 1366, and without further evidence of indefiniteness or confusion, the court finds no merit in this argument either, even giving this term its plain and ordinary meaning.

3. Rim (‘026 Patent, Claims 1, 2, 4, 8, 10, 12, and 15, ‘515 Patent, Claims 1, 3, 11, and 13); Socket Rim (‘275 Patent, Claims 5, 15, and 19); and Support Rim (‘275 Patent, Claim 11)

Defendants also suggest that the terms “rim,” “socket rim,” and “support rim” are used inconsistently, leading to indefiniteness. (Defs.’ Op. Br. (dkt. #105) 82.) While the same numeral is even sometimes used to refer to several, different “rims” in the ‘026 patent, each time, the word “rim” appears to be used according to its plain and ordinary meaning, and the different language used does not necessarily cause undue confusion. After all, “a claim is not indefinite just because it is broad.” *Niazi Licensing Corp.*, 30 F.4th at 1347. Thus, plaintiff argues this is a similar case of the claim being broad enough to encapsulate multiple embodiments. *Id.* Regardless, the court again finds it unlikely that any of the patents’ references would prevent a POSITA from confidently practicing them.

4. Adapter ('515 Patent, Claims 1, 2, 11, 12, and 14)

Defendants further describe the term “adapter” as indefinite, despite previously requesting that the term “adapter” be construed to include the requirement that it is fixed in the cover. Still, defendants note the fact that there are two adapters disclosed in the ‘515 patent and suggest the term is used inconsistently. (Defs.’ Op. Br. (dkt. #105) 82.) As in initial matter, defendants describe numerous terms as “inconsistent” without any actual evidence of inconsistency. Defendants’ expert in particular attempts unpersuasive mental gymnastics to argue that the positioning interface must be separate from the adapter, despite being described as an “element” of the adapter. (Stigge Report (dkt. #83) 48.) Such a reading is also unsupported by other text and the figures of the patent. As previously explained, the court must look at the “claims, read in light of the specification delineating the patent, and the prosecution history.” *Nautilus, Inc.*, 572 U.S. at 901. Read in that larger context, the term “adapter” is certainly not so indefinite that a POSITA would be unable to understand and practice the invention.

5. Exposed portion of flat contact surface has an asymmetrical perimeter ('515 Patent, Claim 11)

Here, defendants argue that the provided figures do not show an asymmetric perimeter, making this term indefinite. (Defs.’ Op. Br. (dkt. #105) 84.) For instance, defendants argue that Figures 39 and 41 show a contactor that would be *symmetrical* if one drew a *horizontal* line through the component, ignoring the fact that the contactor is quite clearly *asymmetric* if one drew a *vertical* line. (Defs.’ Rep. (dkt. #149) 87.) Regardless, the figures, along with the rest of the patent record, make sufficiently clear what is meant by

“asymmetric” and the term is not indefinite. The court certainly hopes defendants will exercise better judgment in paring down their arguments to the more persuasive (or at least to those that pass the proverbial laugh test) for trial.

6. Base receiver ('026 Patent, Claims 1, 10, and 14; '515 Patent, Claims 9 and 19)

Defendants similarly argue that “base receiver” is indefinite because the word “tray” is used inconsistently in the specification. (Defs.’ Op. Br. (dkt. #105) 85.) This inconsistency is also grossly overstated. Notably, “a party challenging patent validity on indefiniteness grounds carries the burden of proof.” *Bosch Auto. Serv. Sols., LLC v. Matal*, 878 F.3d 1027, 1040 (Fed. Cir. 2017) (amended on reh'g in part (Mar. 15, 2018)). As with most of their other indefiniteness claims, defendants’ argument here is premised on thin evidence and overstated argument. Given that defendants have the burden of proof, they have not shown that the term “base receiver” is indefinite.

7. Back Support Surface ('026 Patent, Claims 1, 5, 6, 7, 8, 14, 15, 16, and 18), Docking Support Surface ('026 Patent, Claims 1, 4, 6, 7, 8, 14, 17, and 18)

Finally, defendants yet again give the cursory argument that the meaning of these terms is not clear from the specification, which the court has already noted is not dispositive, meaning that defendants once again have not carried their burden regarding indefiniteness.⁶

⁶ Defendant provides much the same level of argument and evidence for the terms “contactor surface” and “operational surface.” To avoid unnecessary repetition, the court relies on its previous discussions of indefiniteness in this section to find that neither term is indefinite.

B. Non-Infringement

An accused product may infringe the patent either literally or through the doctrine of equivalents. *U.S. Philips Corp. v. Iwasaki Elec. Co.*, 505 F.3d 1371, 1374-75 (Fed. Cir. 2007). “Although infringement under the doctrine of equivalents is a question of fact, ‘[w]here the evidence is such that no reasonable jury could determine two elements to be equivalent, district courts are obliged to grant partial or complete summary judgment.’” *U.S. Philips Corp. v. Iwasaki Elec. Co.*, 505 F.3d 1371, 1375 (Fed. Cir. 2007) (citing *Depuy Spine, Inc. v. Medtronic Sofamor Danek, Inc.*, 469 F.3d 1005, 1013, 1017 (Fed.Cir.2006)). Defendants raise slightly different arguments for non-infringement under each of the patents, which the court examines below.

1. ‘026 Patent

Defendants’ two arguments for non-infringement here are preempted by the court’s claims construction, as defendants argue that the accused products do not have a flexible and unitary cover or a contactor with associated contacts that is fixed in place. This argument relies on the assumption that the court would adopt defendants’ proposed claims constructions. However, because the court found that the cover need not be flexible and unitary and the contactor need not be fixedly placed, defendants’ argument is unavailing.

Plaintiff, in response, requests that the court grant summary judgment *sua sponte* in its favor. *See Judson Atkinson Candies, Inc. v. Latini-Hohberger Dhimantec*, 529 F.3d 371, 384 (7th Cir. 2008) (“if a district court grants one defendant's motion for summary judgment, it may *sua sponte* enter summary judgment in favor of non-moving defendants if granting the motion would bar the claim against those non-moving defendants”). Granting

summary judgment *sua sponte* is appropriate “so long as the losing party was on notice that she had to come forward with all of her evidence.” *Celotex Corp. v. Catrett*, 477 U.S. 317, 326 (1986). However, the Federal Circuit reversed a *sua sponte* grant of summary judgment that was only raised in the non-movant’s opposition brief, as “[the movant] was limited by both time and page length with respect to its response.” *Maxill, Inc. v. Loops, LLC*, 838 F. App’x 534, 538 (Fed. Cir. 2020). Instead, “[h]ad [non-movant] filed its own summary judgment motion,” the movant would have had much more time to respond to any claims. *Id.* Here, movants ProClip and Brodit have obviously not been given a full chance to respond to plaintiff’s request for summary judgment on infringement. Accordingly, the court will deny summary judgment to defendants and decline to grant summary judgment to plaintiff.

2. ‘275 Patent

Regarding the ‘275 patent, defendants first argue that the accused products do not have a cover that extends around a peripheral edge of a front face of the electronic device as contemplated in the patent, as there is a gap where the cover does not shield the edge. (Def.’ Op. Br. (dkt. #105) 39.) Defendants also argue that the court cannot apply the doctrine of equivalents to this claim because the cover retains the device in a completely different way than the accused product (*i.e.*, not flexibly). *Id.* Since the court has already decided the cover does not need to be flexible and fitted in the way defendants suggests, this argument fails. In particular, the court has defined “cover” as “a protective housing adapted to substantially envelop the exterior boundaries of an electronic device,” and defendants’ cover would appear to fulfill that purpose.

Moreover, under the doctrine of equivalents, a device that does not literally infringe a term may nonetheless infringe if there are only insubstantial differences in: “1) the function served by a particular claim element; 2) the way that element serves that function; and 3) the result thus obtained by that element.” *Bondyopadhyay v. United States*, 136 Fed. Cl. 114, 123, *aff'd*, 748 F. App'x 301 (Fed. Cir. 2018). Here, the fact that there is a gap in the periphery of the cover arguably does not prevent it from still acting as a cover, as it will still likely hold and protect the electronic device in and for a reasonably equivalent manner and purpose. Certainly, there is not enough evidence to find that “no reasonable jury could determine two elements to be equivalent.” *Warner-Jenkinson Co. v. Hilton Davis Chem. Co.*, 520 U.S. 17, 39 (1997). As such, this will be a question for the jury.⁷ Accordingly, summary judgment on noninfringement of the ‘275 patent is not warranted.

3. ‘515 patent

Finally, for the ‘515 patent, defendants raise a new argument: there is no direct infringement because that patent affirmatively requires an electronic portable device, which the parties agree defendants do not sell. (Defs.’ Op. Br. (dkt. #105) 46.) In response, plaintiff points to its specific allegations of contributory infringement and inducement, arguing that the accused products *indirectly* infringe the ‘515 patent. (Pl.’s Opp’n. (dkt. #136) 25.) “In order to succeed on a claim of inducement, the patentee must show, first that there has been direct infringement, and second that the alleged infringer

⁷ Defendants also repeat the argument that the accused products do not infringe because the male plug and electrical conductors in the accused products are not fixed in place, which the court has already found is also *not* a requirement for the claims. (Defs.’ Op. Br. (dkt. #105) 40-43.)

knowingly induced infringement and possessed specific intent to encourage another's infringement." *Minnesota Min. & Mfg. Co. v. Chemque, Inc.*, 303 F.3d 1294, 1304–05 (Fed. Cir. 2002) (internal citation omitted); *see also C.R. Bard, Inc. v. Advanced Cardiovascular Sys., Inc.*, 911 F.2d 670, 675 (Fed. Cir. 1990) (“A person induces infringement under § 271(b) by actively and knowingly aiding and abetting another's direct infringement.”).

In response, defendants ask the court to reject this claim because the accused products are missing key elements of the independent claims of the ‘515 patent even when used with a portable electronic device. The prosecution history for the ‘515 patent is instructive on this issue. Specifically, the ‘515 patent was originally rejected as anticipated by previous patent 6,754,343. (Defs.’ Op. Br. (dkt. #105) 52.) In order to avoid anticipation, plaintiff amended the patent application to add the following language to claim 1:

wherein the adapter is configured so that, when coupled to the portable electronic device, the contactor surface is disposed further than any other portion of the adapter from the portable electronic device to form, with the contacts, a male connector configured for coupling to connector contracts within a female receptacle of the external connector.

(Pl.’s Resp. to Defs.’ PFOF (dkt. #135) ¶¶ 202-203.) Thus, for claims 1 and 11, the ‘515 patent requires a “contactor surface [that] is disposed further than any other portion of the adapter from the portable electronic device.” (Defs.’ Op. Br. (dkt. #105) 52.)

Drawing on this clause, defendants argue two ways in which the accused products cannot infringe even when paired with an electronic device: (1) the contactor surface is

actually recessed into the adapter of the product, rather than being disposed further than any other element; and (2) the contactor surface comprises a female connector instead of a male connector. (Defs.' Op. Br. (dkt. #105) 53.) Certainly, defendants may make both arguments to the jury, but they do not dispute that their own, designated expert identified the elements of the accused products differently. (Defs.' Resp. to Pl.'s Additional PFOF (dkt. #145) ¶¶ 67-69.) In particular, at least going by the labeling in the expert's report, the contactor surface on the accused product is arguably disposed further than any other portion of the adapter and the connector is male. (*Id.*) Thus, at minimum, there appears a genuine issue of material fact as to whether the design of the connector surface of the accused product infringes claim 1. As such, the court is unable to grant summary judgment to defendants on this patent, as a reasonable jury very could well find that defendants induced or possessed specific intent to encourage actual, direct infringement and that direct infringement occurred.

C. Priority Dates

According to defendants,

[t]he earliest possible effective filing date to which the Asserted Patents' claims are entitled is November 9, 2015 for the '026 Patent, June 29, 2015 for the '275 Patent, February 23, 2015 for Asserted Claims 1, 2, 3, 4, 8, and 9 of the '515 Patent, and November 9, 2015 for Asserted Claims 11, 12, 13, 14, 18, and 19 of the '515 Patent.

(Defs.' Op. Br. (dkt. #105) 1-2.) In contrast, plaintiff contends that "at least claims 1, 4, 6, 10, 11, 14, 15, 17, 18, and 19 of the '026 patent and claims 1, 2, 8, and 9 of the '515 patent are entitled to a priority date of February 24, 2014." (Pl.'s Op. Br. (dkt. #103) 2.)

“It is elementary patent law that a patent application is entitled to the benefit of the filing date of an earlier filed application only if the disclosure of the earlier application provides support for the claims of the later application, as required by 35 U.S.C. § 112.” *In re Chu*, 66 F.3d 292, 297 (Fed. Cir. 1995). To benefit from an earlier filing date, “[o]bviousness simply is not enough; the subject matter must be disclosed to establish possession.” *PowerOasis, Inc. v. T-Mobile USA, Inc.*, 522 F.3d 1299, 1310 (Fed. Cir. 2008); *see also In re Gosteli*, 872 F.2d 1008, 1012 (Fed. Cir. 1989) (disclosure of scope of earlier application must “clearly allow persons of ordinary skill in the art to recognize that the inventor invented what is claimed” in the written description). “Compliance with the written description requirement is a question of fact but is amenable to summary judgment in cases where no reasonable fact finder could return a verdict for the non-moving party.” *PowerOasis, Inc.* 522 F.3d 1307. Of course, “[w]hen the underlying facts are undisputed, priority date determination is purely a legal question.” *Nat. Alternatives Int’l, Inc. v. Iancu*, 904 F.3d 1375, 1379 (Fed. Cir. 2018).

1. Filing date for ‘026 patent

The ‘986 application was filed February 24, 2014, and plaintiff claims that the ‘026 application is entitled to that priority date. However, at summary judgment, defendants argue that the ‘986 application does not properly disclose the elements of the invention. (Defs.’ Op. Br. (dkt. #105) 37.) Essentially, defendants argue that the ‘986 patent never identifies, in writing or drawing, a “back support surface,” “docking support surface,” or “rim,” despite the fact that independent claim 1 of the ‘026 patent requires a docking

cradle *with* a back support surface, docking support surface, and rim. Patent '026, 32:14-30.

In response, plaintiff argues that some of the figures in the '986 and '026 patents are identical and disclose all three elements. Unfortunately for plaintiff, those elements are never identified or numbered in the '986 patent, as they are in the '026. When evaluating a patent for sufficient written disclosure, a POSITA must be able to “[view] the matter from the proper vantage point ‘of one with no foreknowledge of the specific compound.’” *Novozymes A/S v. DuPont Nutrition Biosciences APS*, 723 F.3d 1336, 1349 (Fed. Cir. 2013) (quoting *Application of Ruschig*, 379 F.2d 990, 995 (C.C.P.A. 1967)). On the other hand, an inventor can meet the disclosure requirement “by such descriptive means as words, structures, figures, diagrams, formulas, etc., that fully set forth the claimed invention.” *Lockwood v. Am. Airlines, Inc.*, 107 F.3d 1565, 1572 (Fed. Cir. 1997). From this perspective, defendants have a colorable argument that these three, essential elements of the independent claim are not sufficiently disclosed even though a back support surface, docking support surface, and rim technically appear in the '986 figures, albeit without labels. As such, there is still a material factual dispute to be resolved at trial: whether a POSITA would recognize what is claimed in the '026 patent. *Novozymes A/S*, 723 F.3d at 1307 “[c]ompliance with the written description requirement is a question of fact”).

2. '275 Filing Date

As for the '275 patent, defendants argue the following requirement for claim 1 is not present in the '986 application:

a cover [100] comprising a panel [104] and a skirt [106] surrounding the panel, the panel [104] comprising an exterior surface, wherein the panel [104] and the skirt [106] form an interior cavity [108] therebetween, wherein the interior cavity [108] is configured and arranged to receive an electronic device [1]...

‘275 Patent 34:7-14. However, plaintiffs point out that the ‘986 application contains the same or nearly the same language:

Protective cover 100 is shown being formed of a flexible unitary protective shell 102 having a flexible center panel 104 surrounded by an integral flexible side skirt 106. Panel 104 and skirt 106 combine to form an interior cavity 108 therebetween that is sized to at least partially cover the side faces and one of the front and back faces of portable electronic device 1, and to further extend around a peripheral edge of an opposite one of the front and back faces of portable electronic device 1. A continuous integral lip 110 extend inward of side skirt 106 and form a mouth opening 112 that communicates with cavity 108.

‘986 Application, 6:22-27.

While the language in the ‘986 provisional application does not work exactly as that in the ‘275 claim, there is no requirement that the written description be identical; “the key question is whether the descriptive matter is present in the original application.” *Nintendo of Am. Inc. v. iLife Techs., Inc.*, 717 F. App’x 996, 1001 (Fed. Cir. 2017). Here, the language between the ‘275 and ‘986 applications are similar enough that a POSITA would likely have notice of what is claimed, especially as someone with “(1) a Bachelor’s Degree in mechanical engineering or a related discipline and at least two years of professional experience working with electronic products and/or electrical connectors, or (2) five years or more of experience in the design or development of electronic products and/or electrical

connectors.” (Stigge ‘026 Report (dkt. #81) ¶ 60.) Because plaintiff did not affirmatively ask for summary judgment for these claims in its own motion, the court will simply deny defendants’ motion for summary judgment on these claims and the jury will decide.

3. ‘515 Filing Date

Finally, defendants argue that the patent prosecution history prevents the ‘515 patent from claiming a priority date before February 23, 2015, again pointing to plaintiff’s addition of the following requirement during the patent’s prosecution in order to avoid overlapping with a previously approved patent:

An adapter. . . wherein the adapter is configured so that, when coupled to the portable electronic device, the contactor surface is disposed further than any other portion of the adapter from the portable electronic device to form, with the contacts, a male connector configured for coupling to connector contracts within a female receptacle of the external connector.

‘515 Patent 34:14-21; (Pl.’s Resp. to Defs.’ PFOF (dkt. #135) 203.)

Given that this clause was necessary to obtain approval of the ‘515 patent, its absence in the ‘986 application would appear dispositive. In its opposition brief, plaintiff glosses over this argument altogether; instead, plaintiff asks this court to focus on figures available in the ‘986 application as it did in arguing for an earlier filing date for the ‘026 patent. (Pl.’s Opp’n. (dkt. #136) 40.) The difference is that plaintiff does *not* point the court to *any* language *or* figures in the ‘986 application supporting the additional, limiting clause in claim 1 of the ‘515 patent. Without support for that essential clause, the court agrees with defendants that claims 1, 2, 3, 4, 8, and 9 of the ‘515 patent are entitled to a

priority date no earlier than February 23, 2015, which is when both language and figures of the crucial limitation were first disclosed.

As for claims 11, 12, 13, 14, 18, and 19, defendants return to their argument that the asymmetric nature of a connector was not disclosed until November 9, 2015, *at the earliest*. (Defs.' Op. Br. (dkt. #105) 69.) However, plaintiff points to figures disclosing an asymmetric rim at least as early as February 23, 2015. (Pl.'s Opp'n. (dkt. #136) 41.) This is sufficient to raise a material factual dispute as to when the asymmetric rim was sufficiently disclosed. The jury will thus be able to decide these claims.

D. Invalidity

Finally, the court turns to defendants' invalidity defense. "If an invalidity defense is asserted only as an affirmative defense to an infringement charge, and not also by way of a counterclaim for a declaratory judgment of invalidity, a finding of noninfringement moots the invalidity issue." *Cave Consulting Group, LLC v. OptumInsight, Inc.*, Fed. Appx., 2018 WL 1410695, *4 (Fed. Cir. 2018). Here, defendants assert invalidity as both a counterclaim and an affirmative defense, so the court must reach the invalidity argument whether or not the jury were to find infringement. (Answer (dkt. #37) ¶¶ 95-109.)

Here, defendants argue that products from both ProClip and third parties were in use *before* the relevant patent priority dates. For each patent, since there are still material disputes as what priority dates apply for certain claims, any invalidity findings will also have to wait until trial. Even if the court were to assume best case scenarios for defendants as to the proper filing date, defendants have *not* provided undisputed evidence that the products they mention actually practice any of the patents' claims. Instead, defendants

simply assert that the products were available and met the requirements of those claims. (Defs.' Op. Br. (dkt. #105) 72.) Given that defendants have the burden of proof on the question of invalidity, such cursory, unsupported assertions are insufficient to grant summary judgment. See *Microsoft Corp.*, 564 U.S. at 97. Accordingly, summary judgment on this point must be denied as well.

III. Plaintiff's Motion for Partial Summary Judgment

Plaintiff's motion for partial summary judgment asks the court (1) to decide the priority dates for certain claims and (2) to find that the patents are not invalid for indefiniteness. As previously noted, defendants have at the very least created a material factual dispute as to whether the '986 patent application provided sufficient written notice to warrant plaintiff's claim to an earlier priority date. As such, the question of priority dates must be decided by the jury. Because the court rejected defendants' arguments in support of their indefiniteness defense, however, the court will grant plaintiff summary judgement on that issue.

ORDER

IT IS ORDERED that:

- 1) Plaintiff's motion to file a reply in support of its proposed findings of fact (dkt. #152) is GRANTED.
- 2) Defendants' motion to supplement Jason Stigge's report (dkt. #118) is DENIED.
- 3) Defendants' motion to strike plaintiff's declaration of James Babcock (dkt. #137) is GRANTED.

- 4) Defendants' motion for summary judgment (dkt. #92) is GRANTED IN PART and DENIED IN PART as set forth above.
- 5) Plaintiff's motion for partial summary judgment (dkt. #96) is GRANTED IN PART and DENIED IN PART as set forth above.

Entered this 27th day of June, 2022.

BY THE COURT:

/s/

WILLIAM M. CONLEY
District Judge